

BRACKETS SNOW RETENTION

FOR USE WITH SOLAR PANELS

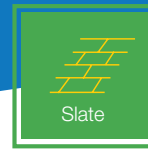

Heavy Duty Bar Extended Snow Bracket

This system is designed for roof applications

- Installation to be completed in accordance with the manufacturer's written specifications and installation instructions.
- Manufactured in Aluminum, Stainless Steel or Brass
- Contact AceClamp® for custom layouts and materials
- Slate applications require a base plate, which is sold separately. (see page 42)
- Compatible for solar arrays

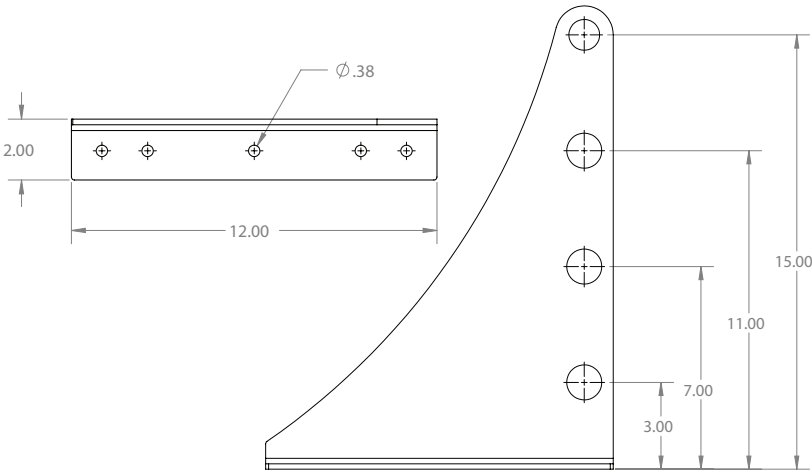
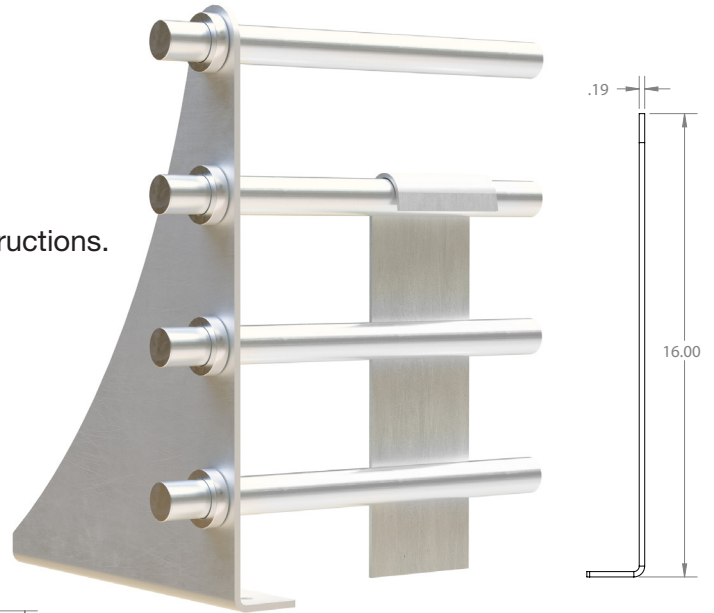

Shown: Part# 5070-HD-4.5

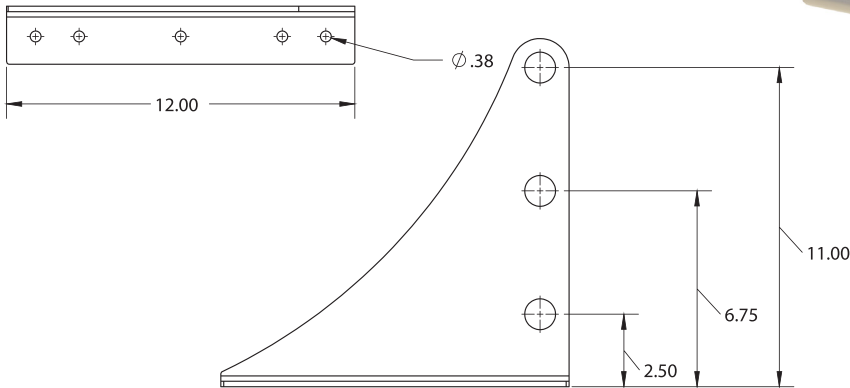
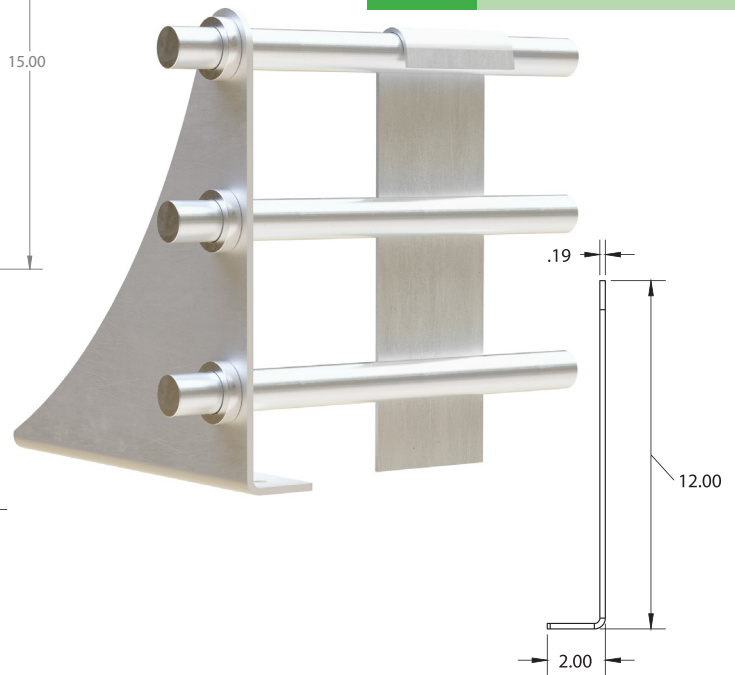

Shown: Part# 5070-HD-3.5



Free Samples and Ordering:

860-351-0686 / www.AceClamp.com

*Based on typical contractor experiences. Photos shown are for representative purposes only. Actual product may vary. Design subject to change without notice. Additional panel profiles & torque specs: aceclamp.com. Always use proper safety equipment when working on a roof. Do NOT use as a personal fall safety device. V021424