



## A2<sup>®</sup>N<sup>™</sup> SSMR Clamp

- Pre-assembled clamp allows for easy installation
- Non-penetrating sliding pin design does not damage the panel
- Available for one, two or three-hole brackets
- Engineered for 1.5" snap-lock SSMR seams
- Aircraft quality aluminum
- All stainless-steel hardware
- *Installs in half the time of competitive products\**



Shown: Part# 5056-N



## ■ Specifications

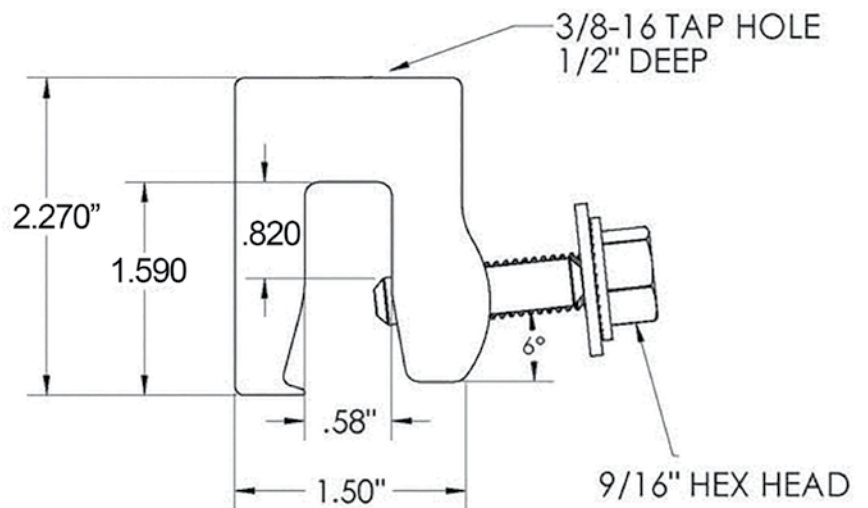
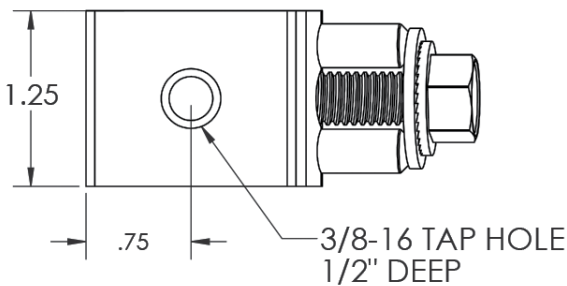

### RECOMMENDED TORQUE SPECS

	22ga steel	Aluminum	Copper
<b>A2<sup>®</sup>-N<sup>™</sup></b>	195	165	n/a

The above is a general recommendation which varies by material type and panel thickness. For additional panel profiles and torque specs visit [www.AceClamp.com](http://www.AceClamp.com)



Free Samples and Ordering:  
860-351-0686 / [www.AceClamp.com](http://www.AceClamp.com)

\*Based on typical contractor experiences. Photos shown are for representative purposes only. Actual product may vary. Design subject to change without notice. Additional panel profiles & torque specs: [aceclamp.com](http://aceclamp.com). Always use proper safety equipment when working on a roof. Do NOT use as a personal fall safety device.